

weberm_t

The Brand of Progress

SRV/SRX



Vibratory Tampers

SRV/SRX

Vibratory tampers from Weber MT: quality that will get you ahead

Excellent compaction results, exemplary operating comfort and rugged design are the essential requirements vibratory tampers must meet. Customers looking to purchase a premium quality tamper need to look no further than the powerful machines being offered by Weber MT.

Regardless of the job requirements Weber MT has a vibratory tamper to meet the customers needs, from earth compaction in sewage and trench construction, a of backfill, shoulder compaction or patching repairs in road construction to their use in gardening and landscaping.

All vibratory tampers from Weber MT are subject to extensive test runs under realistic every-day job site conditions and are available in two models with 4-stroke gasoline engine and one model with Diesel engine. This means for you: practice-proven quality.



Advantages of Weber MT's tampers

- ▶ High tamping outputs.
- ▶ Components optimally matched to each other.
- ▶ Maximum reliability due to the use of high-quality materials.
- ▶ High wear resistance thanks to special material treatment processes such as the ceramic-like coating applied on the guide cylinder.
- ▶ Low maintenance efforts.
- ▶ 2 year warranty.

Vibratory tampers from Weber MT: secure quality for you and your customers.

The four-stroke engines in the SRV 620 and SRV 660 vibratory tampers excel by their outstanding starting behaviour and their low exhaust emission. A special fuel tank with a capacity of 3 l ensures long running times. In addition: integrated fuel filter, tank cap with ventilation and deaeration and possibility to hang up the tank cap during refueling.

A powerful, multi-stage air filtration system guarantees maximum operating reliability and safety.



Maximum operating safety.

Multi-stage air filtration system with cyclone pre-cleaner¹, pre-filter² and main filter³. The air filter of the engine manufacturer is an additional security.

Photo: SRV 620

Additional features

- ▶ A durable tamping system with an active oil lubrication, providing reliable oil support to all components in the crankcase.
- ▶ Damage to the tamping system is being prevented through block impact protection.
- ▶ Highly efficient air filtration systems – SRV 620 and SRV 660 with cyclone pre-cleaner – protect the engine against dirt.
- ▶ Low engine oil warning (SRV 620). During start-up, the electronics reliably measures the engine oil level. An LED lights up to indicate a lack of engine oil.
- ▶ Easy transport through carrying handles and rolls.
- ▶ Hour meter (optional for SRV 620 / SRV 660)
- ▶ High operating comfort through minimized hand-arm vibrations.

Technical data

Typ		SRV 620	SRV 660	SRX 75 DH
Operating weight CECE	kg (lbs)	66 (145)	75 (165)	81 (179)
Shoe width	mm (in.)	280 (11)	280 (11)	280 (11)
Percussion	per min.	700	670	670
Stroke	mm (in.)	65(2.6)	70 (2.8)	70 (2.8)
Impact energy/stroke force	J/kN (ft.lbs/lbs)	80/13 (59/2,920)	88/16 (65/3,595)	88/16 (65/3,595)
Engine manufacturer		Honda GX 100	Robin EH 12	Hatz 1 B 20
Engine type		4-stroke gasoline	4-stroke gasoline	Diesel
Engine output max.	kW (HP)	2.1 (2.9)	2.6 (3.6)	3.5 (4.8)
Power output at operating speed	kW (HP) at r.p.m.	1.8 (2.5) at 4,100	2.3 (3.1) at 3,600	3.4 (4.6) at 3,600

We reserve the right to alter specifications.

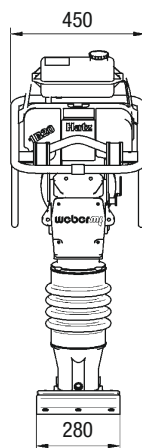
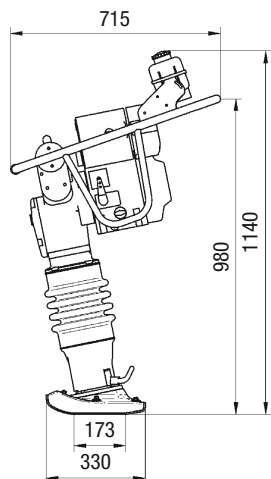
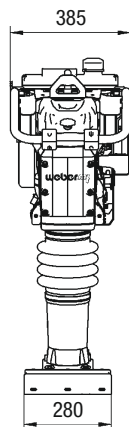
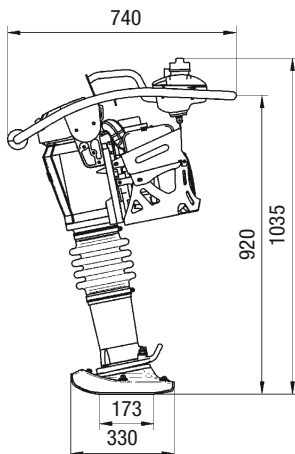
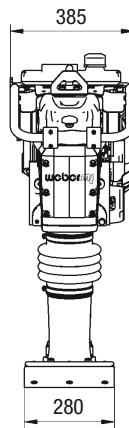
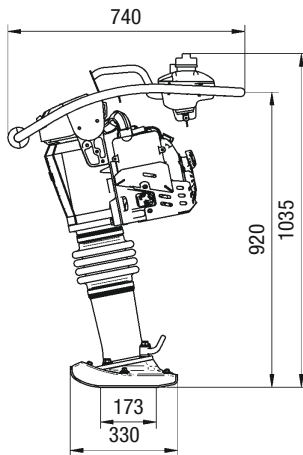

Dimensions in mm.

Weber Maschinentechnik GmbH

Im Boden 5-8, 10 · 57334 Bad Laasphe · Germany · P.O. Box 21 53 · 57329 Bad Laasphe · Germany

Phone: +49 (0) 27 54/3 98-0 · Fax: +49 (0) 27 54/3 98-101 · E-Mail: info@webermt.de · Internet: www.webermt.de